

A Study on Interleave Division Multiple Access

Chirag R. Shah

Electronics & Telecommunication Engineering, University of Mumbai, India.

Abstract: As wireless broadband communication has been experiencing a tremendous growth in past few year, the demands for various new & advanced multiple access techniques is increasing consistently. We can experience many new multiple access techniques in 3G & 4G. Here in this article we propose the multiple access technique IDMA which was developed with the view of achieving something more in terms of speed and capacity than what we had in 3G. The most important in IDMA is turbo-code which has increased the efficiency of 4G to a larger extent. By using these turbo codes with interleave division multiple excess the data rates 4G technology has been increased significantly. The basic idea behind this article is to lead down how by using interleaver division multiple accesses we can achieve higher coding gain, capacity, high speed (both for uploading & downloading) by using turbo codes along with IDMA.

Keywords: *Interleavers, Multiple accesses, Turbo codes, Orthogonality.*

1. Introduction

As we go ahead in the current scenario of wireless digital communication, multiple access technique has been significant nowadays. Over the years, the need for high bandwidth, high efficiency, and high data rate has increased to a larger extent. To meet this ever-growing demand has lead down the foundation of most innovative Multiple Access Technique viz. IDMA (Interleave Division Multiple Access). The main reason to switch to IDMA from OFDM is the complexities that were observed in OFDM. In OFDM, for all the signals to maintain orthogonality amongst themselves was the major challenge and many times it can be observed that even if a single signal on the entire bandwidth losses orthogonality then all the signals on that bandwidth are affected. To overcome all theses IDMA was introduced which works on a different principle than that of OFDM and gives a much better way of communication. Before starting with all the concepts involved in both OFDM (for better understanding) and IDMA it is to understand the influence of multiple access technologies I communication system. Whenever a signal is transmitted from mobile to base station or vice versa, the signal uses a dedicated bandwidth, this bandwidth is been allocated to multiple users from its respective service providers; the multiple access techniques allows all the users to communicate with the base station of its respective service providers or with any other users of any particular service providers efficiently. This is due to the reason that the spectrum of allocated bandwidth is high but limited with respect to the load of number of users occupying it, and owing to this there a very high probability that signal may get faded, her multiple access techniques helps in sharing the capacity of the bandwidth over the given region and allows the signal to flow flawlessly. During this process of signal propagation, multiple access techniques also take care that the quality of the signal should remain distinct the propagation. When we go across to 4G from 1G, all the communication system have got its own multiple access techniques, therefore it can be stated that multiple access techniques are something that can be taken as the introductory node of all the communication technologies. The one used in 3G is OFDM (Orthogonal Frequency Division Multiplexing), this has given a huge boost not only to 3G but it has led down the foundation of modern communication with 3G that has excelled to give best date rates within very few time and with the best speed. IDMA (Interleave Division Multiple Access) was brought to the world when it was realizing the need to overcome the complexities in OFDM which are discussed further in the article. IDMA is also called as the advanced version of CDMA [2] where the problem of MUD which was the huge set back in CDMA is easily overcome [1]. Let us now see the details of it in the further sections.

1.1. IDMA Principle

The very first thing that needs to understand is: Interleaver is the heart of IDMA system. IDMA is often called as the next generation multiple access techniques for CDMA [2] and also for OFDM. In IDMA different users can use different types of Interleavers mentioned in the further section and also interleavers are used to differentiate the signals on entire bandwidth spectrum [3]. Since different users are using different interleavers it optimizes ISI [2]. Interleaver works in a very special fashion where the data at the input end of interleaver is in matrix form, the matrix takes the data row-wise and the output of the matrix is column-wise [2].

The most important thing in interleaver is that it is not mandatory for the signals to be orthogonal as it is in OFDM [2] and this reduces the complexities of IDMA to a greater extent [4]. This is the main reason why IDMA was brought up than OFDM (as discussed in the previous section), because in OFDM for all the signals that are propagating it is very much necessary to be orthogonal and in case any signal losses its orthogonality then ISI can easily occur. This behavior of signal fading is overcome by the use of IDMA (interleavers), and this gives the better quality of signals at the receiving end. This also enables IDMA to give better data rates, improved bandwidth efficiency where the entire bandwidth can be utilized in an optimized manner [4].

1.2. Design of IDMA System

As discussed in the previous section, IDMA is the most versatile multiple access techniques at present in the communication technology. Let us now have a look at its system model to have a brief idea of about how exactly the signals are being processed in IDMA to give the optimistic results.

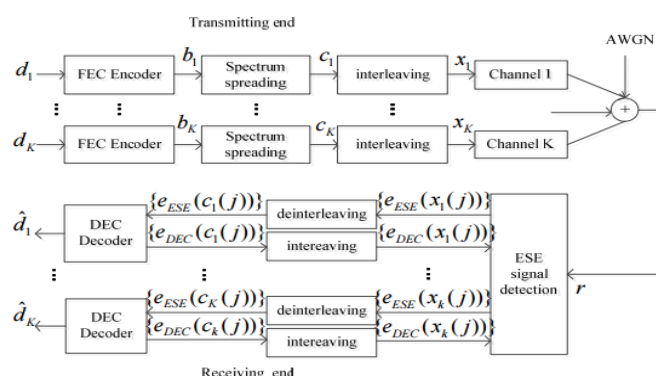

Figure 1.
IDMA System [4].

In IDMA system, the main challenge is to avoid ISI in the non-orthogonal signals, since here signals are not orthogonal as in OFDM [3]. We also have a multiple access technique named CDMA (Code Division Multiple Access) where the symbols are not orthogonal and here the symbols are transmitted via asynchronous transmission and due to these problems like ICI and ISI are encountered in CDMA also the problem of MUD takes place in CDMA due to this type of transmission [3, 4]. Therefore to overcome all these issues in IDMA is used where all the signals are separated using interleavers and hence, IDMA can be called as a special form of CDMA [4]. Now, let us get into the details of fig.1 which shows how the symbols are propagating in IDMA. The very first block is for encoding where the symbols are encoded and processed further to spread spectrum. Here, at this stage, every signal gets entire bandwidth to use and here starts the role of multiple access schemes where they need to manage all the symbols on the allocated bandwidth inefficient manner so as to utilize the bandwidth up to its best and to yield the best possible results. As per the discussion in the introduction section, the multiple access technique allows the signals to propagate through the spectrum, it is very much essential for multiple access techniques to maintain the capacity of the spectrum intend so that it can be used at the most. Once the signals channel is occupied by the signals, all the signals are now interleaved using any of the interleaving techniques, this forms the unique block of the system where symbols can be identified based on their respective interleaver, and this helps to keep the communication easy and faster. Further, the signals sent across to receiving end via channels wherein between channels and the receiving end the signals travel across the sky and this is the time when the signal is most likely to be affected by interference (MAI). The first block at the receiving end is of ESE (Elementary Signal Estimator) block, the main function of ESE block is to detect the interference and it also resolves interference partially. This is also one of the unique blocks at the receiving end of IDMA system which makes it special to overcome with interference at the receiver's end. Further, the signals are sent over to deinterleaver where the signal is separated from the respective interleavers and then passed on for decoding to the block of decoder post which the signal reaches its destination successfully. The above-mentioned procedure is repeated for all the signals waiting in the queue for being transmitted [3].

1.3. Types of Interleavers

So far we have seen that, interleavers form an integral part of IDMA where each signal is interleaved and transformed. Let us now go in brief about the different types of interleavers used to spread the signals across the available spectrum in various patterns as listed below.

1.4. Random Interleavers

This is the easiest way for the symbols to spread across the spectrum using interleavers. In random interleavers, the concept of pseudo-random computation is used [5]. All the symbols that are to be transmitted are scrambled randomly in an arbitrary fashion [2,4,5,6]. Since the data is scrambled in an arbitrary way this helps to reduce the burst error of the channels at the receiving side [5]. In random interleavers, data are arranged using an arbitrary series and while decoding at the receiving end the same sequence is required to be used. Following is one such example of data transmission using random interleavers, where at receiver end; the data can be regenerated using the same series of permuted indices of generation. The difficulty of using random interleaver is that the separation of users will be very difficult in this case since it will occupy a lot of memory at both transmitter and receiver end [5] and this will occupy most of its bandwidth making it inefficient for transmission of multiple symbols which ultimately affect the data rates, also it will increase the computational complexity at the receiving end as all the received users will be separated, this may cause the signal to delay and hence affecting the transmission rate [5].



Figure 2.
Scrambling of data in Random Interleavers [2].

1.5. Master Random Interleavers

Master Random Interleavers is similar to random interleavers in its functioning but it overcomes the drawbacks encountered in random interleavers. The major setback of random interleavers is that it is very difficult to separate the users. Here, in this case, the above-mentioned issue can be avoided.

IDMA uses interleavers for transmission, therefore, it is essential for the BS (Base Station) to store all the interleavers with the respective patterns used, and therefore interleavers will definitely consume the memory making the spectrum less efficient to handle more number of users [6]. Apart from this at an initial stage, it is also required for BS and MS (Mobile Station) to share the pattern of interleavers used for communication [6].

To overpower all this master random interleavers also called as power interleavers is used, where a master interleaver pattern is assigned [6]. Now let us understand how this is achieved. The number of interleavers used will surely be an integer, therefore let's assume that since there are K interleavers, so the total interleavers generated can be expressed as $\pi^k = \varphi^k$.

Here, $\varphi^k(c) = \varphi_1(c) = \varphi(c), \varphi_2(c) = \varphi(\varphi(c)), \varphi_3(c) = \varphi(\varphi(\varphi(c))) \dots$ And so on [6].

Therefore, by above principle, every interleaver can be expressed as a power of φ .

The basic idea here is that, if φ is an ideal random permutation then all are $\{\varphi^k\}$, and these permutations are almost independent of each other [6].

After the above process is completed, each BS assigns the power index of K to each user, which then generates $\{\varphi^k\}$ for user K at MS.

The signals transmitted by this phenomenon of pattern generation increases the efficiency of the spectrum bandwidth in terms of handling the user signals and to process it from BS to MS [6].

1.6. Tree Based Interleaver (TBI)

main objective here in tree-based interleaver is to overcome the issue of memory consumption in random and power interleaver and also to overcome the computational complexities encountered in each of them respectively [6].

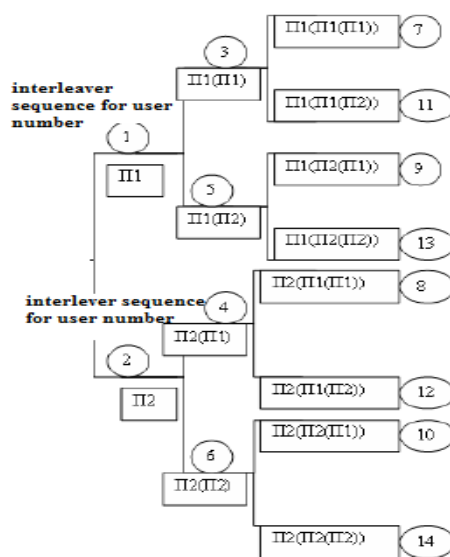

Figure 3. Masking of interleavers of TBI [6].

The concept of TBI is quite similar to random interleaver, but here instead of one interleaver (like in random interleaver) two interleavers are selected at random, these two interleavers are selected since it is a tree-based concept so it has got multiple branches as seen in below diagram, so the two interleavers are selected to separate it out (two interleavers) to 2 different branches observed in below fig.3 [6]. The two interleavers elected at random are termed as the master interleavers [6]. The two interleavers are select in such a way that one is odd and one is even; where the even number of users goes downside whereas odd goes upside as seen in fig. 3. The main benefit of using this ideology is that it increases the utilization of the spectrum up to its optimized level with minimal ISI [6]. Let us now study how the above-mentioned concept works practically, for this let's have a look at the fig.3 which symbolizes how TBI is implemented.

In the above diagram, the starting point is mentioned as interleaver sequence for user number, where each incoming signals is been allotted interleaver. Each incoming signal is given a unique interleaver in alternate fashion; in the above fig. the very first signal is given the assigned with interleaver π_1 whereas the second with π_2 [6]. Further, the next incoming signals will be allotted with the interleaver of $\pi_1(\pi_2)$ and the subsequent fourth one with $\pi_2(\pi_1)$...And so on this tree progress further as shown in the fig above [6].

In TBI, since the signals are spread over multiple branches it helps a lot to improve the memory utilization of the channel as compared with the random interleaver, but somehow this memory consumption is quite more than master random interleaver [6].

Therefore, TBI can attain the best utilization of memory across the spectrum bandwidth which allows transmitting more signals over the channel which in turn increases the data rate of the system and makes it efficient.

1.7. Performance Parameter: BER (Bit Error Rate) OF IDMA

In digital communication, various parameters are used to compare the performance of digital system one over the other, so as to get the better understanding of the systems that are being compared.

The definition of BER can be stated as “the percentage of bits which are corrupt within the total available bits; it is usually expressed in the negative power of 10 [7].” BER indicates that what is the total number of bits that

are affected by the total number of bits that were transmitted [7]. To measure BER, BERT (Bit Error Rate Testers) is used [7]. BER can be expressed mathematically as [4]:

$$\text{BER} = \frac{\text{No. of Error Bits}}{\text{No. of Total Bits}}$$

The analysis of BER has an effect on 3 parameters viz. Bandwidth, Interference and Transmission Power [7].

2. Results and Analysis

Results and analysis (Chirag Shah et al., 2016) is basically aimed to provide the analysis of IDMA wrt to BER, which indicates that as the BER value obtained in IDMA is highly stabilized when the SNR (Signal to Noise Ratio). Where SNR is taken in DB (decibels).

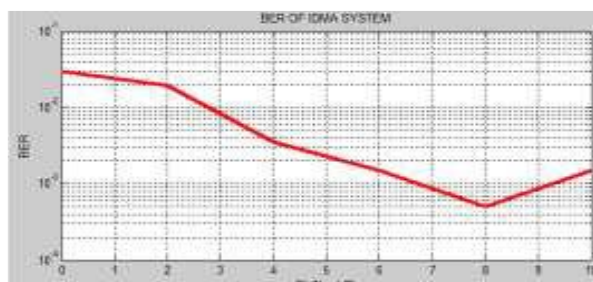

Figure 4.
BER response of IDMA System.

The below tables shows the different values obtained for BER versus different values of SNR.

Table 1.
SNR v/s BER values of IDMA (in presence of noise).

SNR (in dB)	BER
0	0.03
2	0.0195
4	0.0335
6	0.0015
8	0.0005
10	0.0015

The above table indicates that, even when the values of SNR is increased the BER is giving highly stabilized value which indicates that IDMA is the most suitable multiple access technology for advanced digital communication.

3. Conclusion & Future Scope

The above study on IDMA has helped to understand the concept of IDMA clearly; where the focus was on the key technology in IDMA i.e. interleavers. The main idea of this article was to have a brief understanding of how the signals are transmitted through wireless media from transmitter to receiver and how the signals attains the optimized BER with least possible signal fading. After going through all the aspects mentioned above it can be concluded that the use of separate interleavers for each and every signals helps to attain the best possible results in terms of high data rates, maximum efficiency and the most important is that it can support a huge number of users to communicate within the allocated bandwidth spectrum. In regards with all the above advantages IDMA have got, it will be very interesting to see the role of IDMA in 5G (where the proposed multiple access technique is BDMA an advanced version of IDMA) as it has already left an outstanding impact in 4G.

References

- [1] L. Ping, L. Liu, K. Wu, and W. K. Leung, "Interleave division multiple-access," *IEEE Transactions on Wireless Communications*, vol. 5, no. 4, pp. 938-947, 2006.
- [2] E. Khan and D. Khan, "Evolution of IDMA," *International Journal of Engineering Science Invention Research & Development*, vol. 1, p. 1, 2014.
- [3] N. Pragati and H. Jadhav, "Implementation of IDMA system for estimation of multiple access interference," presented at the Fourth Post Graduate Conference, 2015.
- [4] R. S. Chirag, "Performance and comparative analysis of OFDM, OFDM-CDMA & OFDM-IDMA systems," *International Journal of Engineering Research & Technology*, vol. 5, no. 4, pp. 1-6, 2016.
- [5] S. Deepti, S. Avinash, and Y. Dayanand, "Generation of interleaver for IDMA," *International Journal of Engineering Science Invention Research & Development*, 2014.
- [6] K. Choudhary and P. Sharma, "Interleavers for IDMA technology: A comparison survey," *International Journal of Advanced Research in Computer and Communications*, vol. 1, no. 2, pp. 55-61, 2012.
- [7] C. R. Shah, "Analytical and comparative Analysis of Ofdm," *International Journal of Engineering Trends and Technology*, vol. 42, no. 5, 2016.